

McIntosh[®]
OWNER'S MANUAL

C39
AUDIO/VIDEO
CONTROL
CENTER

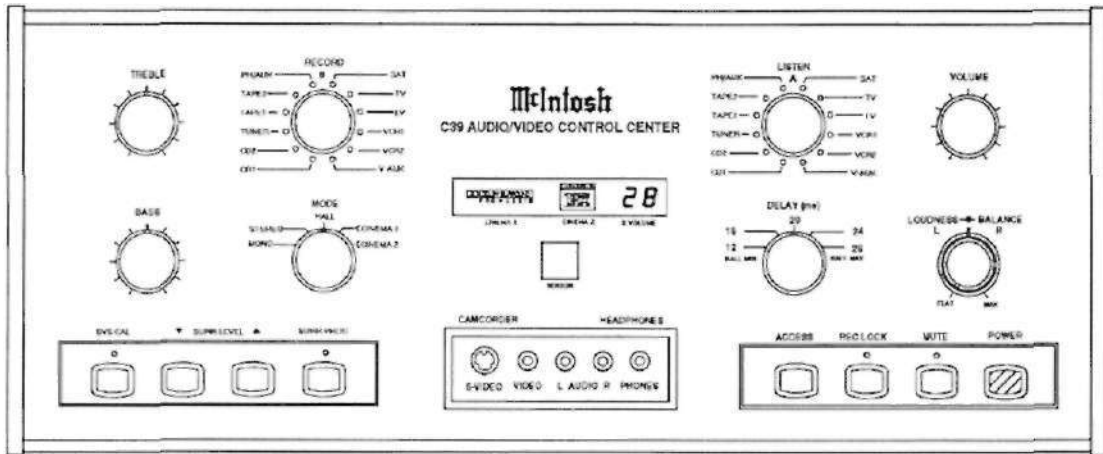

OWNER'S MANUAL



C39
AUDIO/VIDEO
CONTROL
CENTER

**IMPORTANT
SAFETY
INSTRUCTIONS**

**THESE
INSTRUCTIONS
ARE TO PROTECT
YOU AND THE
McINTOSH
INSTRUMENT.
BE SURE TO
FAMILIARIZE
YOURSELF
WITH THEM**

1. Read all instructions - Read the safety and operating instructions before operating the instrument.
2. Retain Instructions - Retain the safety and operating instructions for future reference.
3. Heed warnings - Adhere to warnings and operating instructions.
4. Follow Instructions - Follow all operating and use instructions.

WARNING: TO REDUCE RISK OF FIRE OR ELECTRICAL SHOCK, DO NOT EXPOSE THIS INSTRUMENT TO RAIN OR MOISTURE.

5. Power Sources - Connect the power supply only to the type described in the operating instructions or as marked on the unit.
6. Power-Cord Protection - Route power-supply cords so that they are not likely to be walked on or pinched by items placed upon or against them, paying particular attention to cords at plugs, convenience receptacles, and the point where they exit from the instrument.
7. Ventilation - Locate the instrument for proper ventilation. For example, the instrument should not be placed on a bed, sofa, rug, or similar surface that may block ventilation openings; or, placed in a built-in installation, such as a bookcase or cabinet, that may impede the flow of air through the ventilation openings.
8. Heat - Locate the instrument away from heat sources such as radiators, heat registers, stoves, or other appliance (including amplifiers) that produce heat.
9. Wall or Cabinet Mounting - Mount the instrument in a wall or cabinet only as described in the owner's manual.
10. Water and Moisture - Do not use the instrument near water - for example, near a bathtub, washbowl, kitchen sink, laundry tub, in a wet basement, or near a swimming pool, etc.
11. Cleaning - Clean the instrument by dusting with a dry cloth. Clean the panel with a cloth moistened with a window cleaner.
12. Object and Liquid Entry - Do not permit objects to fall and liquids to spill into the instrument through enclosure openings.
13. Nonuse Periods - Unplug the power cord from the AC power outlet when left unused for a long period of time.
14. Damage Requiring Service - Service must be performed by qualified service personnel when:
 - A. The power supply cord or the plug has been damaged; or
 - B. Objects have fallen, or liquid has been spilled into the instrument; or
 - C. The instrument has been exposed to rain; or
 - D. The instrument does not appear to operate normally or exhibits a marked change in performance; or
 - E. The instrument has been dropped, or the enclosure damaged.
15. Servicing - Do not attempt to service beyond that described in the operating instructions. All other service should be referred to qualified service personnel.
16. Grounding or Polarization - Do not defeat the inherent design features of the polarized plug. Non-polarized line cord adaptors will defeat the safety provided by the polarized AC plug.

17. CAUTION: TO PREVENT ELECTRICAL SHOCK DO NOT USE THIS (POLARIZED) PLUG WITH AN EXTENSION CORD, RECEPTACLE OR OTHER OUTLET UNLESS THE BLADES CAN BE FULLY INSERTED TO PREVENT BLADE EXPOSURE.

ATTENTION: POUR PREVENIR LES CHOCS ELECTRIQUES PAS UTILISER CETTE FICHE POLARISEE AVEC UN PROLONGATEUR, UNE PRISE DE COURANT OU UNE AUTRE SORTIE DE COURANT, SAUF SI LES LAMES PEUVENT ETRE INSEREES A FOND SANS EN LAISSER AUCUNE PARTIE A DECOUVERT.



The lightning flash with arrowhead, within an equilateral triangle, is intended to alert the user to the presence of uninsulated "dangerous voltage" within the product's enclosure that may be of sufficient magnitude to constitute a risk of electric shock to persons.



CAUTION: TO PREVENT THE RISK OF ELECTRIC SHOCK, DO NOT REMOVE COVER (OR BACK). NO USER-SERVICEABLE PARTS INSIDE. REFER SERVICING TO QUALIFIED PERSONNEL.



The exclamation point within an equilateral triangle is intended to alert the user to the presence of important operating and maintenance (servicing) instructions in the literature accompanying the appliance.

WARNING: THIS UNIT IS CAPABLE OF PRODUCING HIGH SOUND PRESSURE LEVELS. CONTINUED EXPOSURE TO HIGH SOUND PRESSURE LEVELS CAN CAUSE PERMANENT HEARING IMPAIRMENT OR LOSS. USER CAUTION IS ADVISED AND EAR PROTECTION IS RECOMMENDED WHEN PLAYING AT HIGH VOLUMES.

Your decision to own this piece of McIntosh Stereo Equipment ranks you at the very top among discriminating music listeners. You now have "The Best". The McIntosh dedication to "Quality", is assurance that you will receive thousands of hours of musical enjoyment from this unit.

Please take a short time to read the information in this manual. We want you to be as familiar as possible with all the features and functions of your new piece of McIntosh. This will ensure that you receive all the performance benefits this instrument can offer you, and that it will become a highly valued part of your home music system.

The serial number, purchase date, and McIntosh Laboratory Service Contract number are important to you for possible insurance claim or future service. Record this information here.

Serial Number	Purchase Date
Service Contract Number	

Upon application, McIntosh Laboratory provides a Service Contract to the original purchaser. Your McIntosh Authorized Service Agency can expedite repairs when you provide them with the Service Contract.

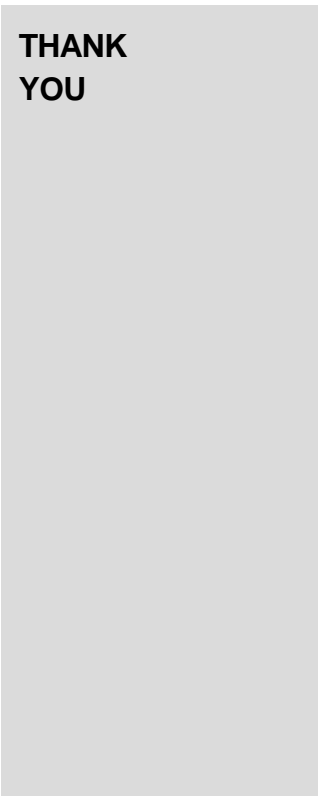

SERVICE CONTRACT. 4

INTRODUCTION. 5, 6

HOW TO INSTALL THE C39. 6

HOME THEATER AUDIO CHANNEL CONFIGURATION WITH
 DOLBY PRO LOGIC™ AND HOME THX® AUDIO. 7

FRONT PANEL CONTROLS, SWITCHES AND PUSHBUTTONS. 8, 9, 10, 11, 12, 13

C39 HAND HELD REMOTE CONTROLLER. 13, 14, 15

THE REAR PANEL AND HOW TO MAKE CONNECTIONS. 15, 16, 17, 18, 19, 20, 21

HOW TO SET UP YOUR McINTOSH HOME THEATER. 21, 22

HOME THEATER LAYOUT. 23

HOME THEATER HOOKUP. 24

McINTOSH HOME THEATER SURROUND SOUND
 VOLUME LEVEL CALIBRATION. 25, 26, 27, 28

SPECIFICATIONS. 29, 30

CUSTOM INSTALLATION DRAWING. 31

FOLD-OUT DRAWINGS OF FRONT AND BACK PANELS OF C39. 32

**McINTOSH
THREE YEAR
SERVICE
CONTRACT**

TAKE ADVANTAGE OF 3 YEARS OF CONTRACT SERVICE. . .
FILL IN THE APPLICATION NOW.

Your C39 Audio/Video Control Center will give you many years of satisfactory performance. If you have any questions, please contact,

Mcintosh Laboratory Inc.

2 Chambers Street
Binghamton, New York 13903-2699
Phone: 607-723-3512

An application for A THREE YEAR SERVICE CONTRACT is included with this manual. The terms of the contract are:

1. If the instrument covered by this contract becomes defective, McIntosh will provide all parts, materials, and labor needed to return the measured performance of the instrument to the original performance limits free of any charge. The service contract does not cover any shipping costs to and from the authorized service agency or the factory.
2. Any McIntosh authorized service agency will repair all McIntosh instruments at normal service rates. To receive the free service under the terms of the service contract, the service contract certificate must accompany the instrument when taken to the service agency.
3. Always have service done by a McIntosh authorized service agency. *If the instrument is modified or damaged as a result of unauthorized repair the service contract will be cancelled.* Damage by improper use or mishandling is not covered by the service contract.
4. The service contract is issued to you as the original purchaser. To protect you from misrepresentation this contract cannot be transferred to a second owner.
5. Units in operation outside the United States and Canada are not covered by the McIntosh Factory Service Contract, irrespective of the place of purchase. Nor are units acquired outside the USA and Canada, the purchasers of which should consult with their dealer to ascertain what, if any, service contract or warranty may be available locally.

Mcintosh Laboratory has earned a world wide reputation for the technical superiority of its contributions to high quality sound reproduction. The advanced level of Mcintosh product innovations has integrity proven by time. The legendary reliability of Mcintosh products is a matter of record since 1949. The "Classic Mcintosh" design is acknowledged as the most outstanding in the audio industry.

Mcintosh products are designed to be maximum "User Friendly". Anyone can enjoy using them. Ease of maintenance is another Mcintosh design philosophy that contributes to the long useful operating life of all Mcintosh products.

The C39, Audio/Video Control Center is a full featured remote control center for a complete Mcintosh Home Theater System. It provides six audio channels with the added features of video switching.

The C39 includes all the required Dolby Pro Logic™ decoding circuits to reproduce Dolby Surround™ encoded movie soundtracks.

You also can enjoy the enhanced movie sound track reproduction possible from Home THX® Audio processing circuits by having your Mcintosh dealer install the optional Mcintosh THX-M Module in your C39. The Home THX® Audio System is a licensing program of Lucasfilm Ltd., which defines new technologies and quality standards for accuracy in home theaters. The C39 includes a built-in noise generator and the controls necessary for accurate volume level calibration of all six channels when setting up a home theater.

The C39 has the added feature of the Mcintosh designed "HALL" signal processing circuits. The "HALL" feature allows you to enhance the realism of two channel program sources such as a compact disc. The Left and Right signals are reproduced through the Left and Right Front loudspeakers. The same signals are combined and fed to the center channel loudspeaker as mono center fill. The combined left and right are also fed to a digital processor with variable time delay for the surround loudspeakers. If a subwoofer is used in the system, it will also operate in the "HALL" mode.

The C39 includes a 25 pin connector on the rear panel to accommodate a single sub-miniature "D" computer type cable which fits a similar connector on a Mcintosh MC7106 six channel power amplifier. This cable carries all six audio signals and AC power control to the MC7106 for a complete Mcintosh Home Theater System.

The C39 has built-in capability for remotely controlling two separate listening areas. The LISTEN signals are defined as Area "A" which is usually the main area where all the equipment is located. The RECORD signals are available at a pair of outputs marked "B", and can be used for a remote area with its own dedicated power amplifier and pair of speakers. The desired program can be selected in Area "B" with the HR39 Hand Held Remote Controller transmitting to a wall mounted IR sensor, or from a WK-1 keypad.

Data ports are provided for twelve audio and video remote controlled accessories. This feature allows you to control a compatible unit by transmitting with its hand held remote controller directly to a C39 sensor. Another data port connects to the optional Mcintosh HC-1 Home Controller to allow control of accessories or appliances.

The optional Model RCT-1, Remote Control Translator is also available to interconnect with the C39. The RCT-1 is a learning device which will allow the C39 to remotely control other brands of products.

The convenience of C39 remote control operation is enhanced by its capability to directly interface with the Mcintosh CR10 Remote Control System. The CR10 can add an additional four remote areas of control.

The C39 includes twelve pairs of high level audio inputs. Seven inputs are for all the tradi-

INTRODUCTION

tional audio program sources. A pair of low level inputs is included for a moving magnet phono cartridge. Six of the audio inputs are for the audio portion of an audio/video signal. Six matching standard and S Video inputs are also included. The C39 will simultaneously switch the six video and corresponding audio signals.

The C39 uses digital Logic integrated circuits to drive Electromagnetic Switches for all input, output and operating functions. This is the most reliable and distortion free switching available.

Separate Record and Listen circuits allow recording from one source while listening to another with audio or audio/video signals. A continuously variable Active Loudness control allows loudness compensation to be selected for any setting of the volume control. The Loudness control circuit elements are removed from the circuit path when the control is in the flat or fully counterclockwise position.

Bass and Treble tone controls provide 12dB of boost or cut. At the center "Flat Response" or detent position of the tone controls, all tone control circuit elements are removed from the signal path. Other features include a precision digital driven six channel volume control, front panel digital volume level indicator and Balanced outputs for the Left and Right output signals.

Front panel Camcorder inputs and a headphone output are also provided. These connections are hidden behind a motor driven door which is opened and closed by a convenient front panel Access pushbutton. The McIntosh C39 "Classic McIntosh" all glass front panel has all control, switch and pushbutton nomenclature illuminated.

The McIntosh Home THX Audio licensed C39 Audio/Video Control Center, MC7106 six channel power amplifier and a set of McIntosh HT Series Home Theater loudspeakers will make a perfect "**McIntosh Quality**" Home Theater system. Your McIntosh dealer can assist you in setting up all the various components of your McIntosh Home Theater to ensure you will receive the best possible performance.

DOLBY SURROUND, PRO LOGIC and the Double-D Symbol are trademarks of Dolby Licensing Laboratory. Home THX®Audio is a registered trademark of Lucasfilm Ltd.

HOW TO INSTALL THE C39

The C39 can be placed upright on a table or shelf, standing on its own plastic feet. It can also be installed in an optional McIntosh L74 equipment cabinet. Follow the mounting instructions enclosed with the L74 cabinet.

The C39 can be custom installed in a piece of furniture or cabinet of your choice. The required panel cutout and unit dimensions are shown on Page 31 of this manual.

Always provide adequate ventilation for your C39, even though it develops very little heat. Cool operation insures the longest possible operating life for any electronic instrument. Do not install your C39 directly above a heat generating component such as a high powered amplifier. In a system stack, the power amplifier should always be at the top. If all the components are installed in a single cabinet, a quiet running ventilation fan can be a definite asset in maintaining all the system components at their coolest possible operating temperatures.

A custom cabinet installation should provide the following recommended minimum spacing dimensions for cool operation. Allow at least 1 1/2 inches (3.8cm) above the unit so airflow is not obstructed. Allow 17 1/2 inches (44.5cm) depth behind the mounting panel, which includes clearance for connectors. Allow 1-1/8 inches (2.9cm) in front of the mounting panel for knob clearance.

HOME THEATER AUDIO CHANNEL CONFIGURATION WITH DOLBY PRO LOGIC™ AND HOME THX AUDIO

All movies produced by major film companies have Dolby Stereo soundtracks. When they reach you via home video sources, the Dolby Surround encoding remains intact. Dolby Pro Logic relies on the same decoding technology as the professional cinema processors to decode the movie sound tracks that are found on video. The decoding process results in four separate sound tracks which are Left Front, Center, Right Front, and Surround. The Dolby Pro Logic decoded surround signals are monaural, but are reproduced by a non-directional loudspeaker on each side of the listening area to help diffuse the sound. The Dolby Surround concept is the heart of the Home Theater audio and video experience.

Dolby Surround encoding is also used for MTS and satellite broadcasts as well as other audio-only program sources such as compact discs. Use the C39 CINEMA 1 mode with its Dolby Pro Logic processing to enjoy listening to these other program sources.

Home THX Audio circuits further process all the Dolby Pro Logic decoded signals including the generation of separate spatially expanded left and right surround signals. Home THX Audio also specifies that a subwoofer be used. A Home THX Audio system therefore requires six discrete audio channels and six corresponding loudspeakers.

The C39 provides six audio channels to take full advantage of the exciting sound reproduction capabilities of a Dolby Surround encoded movie sound track. When the McIntosh THX-M module is installed in the C39 the audio enhancements possible by Home THX Audio signal processing also will be available.

Descriptions of the functions of each channel of a Dolby Surround soundtrack as decoded by Dolby Pro Logic and the addition of Home THX Audio processing will assist you in better understanding the use of the various controls, switches and operating procedures of your C39.

DOLBY SURROUND LEFT FRONT and RIGHT FRONT

These two channels are stereo channels in the traditional sense. The left and right signals provide ambience, depth and spaciousness for reproduction of music and sound from a Dolby Pro Logic decoded movie soundtrack. The front channels also reproduce similar information from a two channel stereo source such as a compact disc or audio tape.

DOLBY SURROUND CENTER FRONT

Dolby Surround movie soundtracks are encoded with a Center channel, which also includes dialog information, to increase the realism of the home theater experience. The Dolby Pro Logic decoded Center channel is reproduced through a loudspeaker placed in the front center location, either above or below the viewing screen. A Center loudspeaker provides greater intelligibility and localization of a movie dialog regardless of the seating position.

DOLBY SURROUND LEFT and RIGHT SURROUND

Dolby Surround soundtracks are encoded with a specially processed surround sound signal. When decoded by Dolby Pro Logic processing circuits, the surround sounds can include all types of acoustical information and sound effects that enhance your listening enjoyment. The Dolby Pro Logic decoded surround sound channel is monaural, however, it is reproduced through two separate loudspeakers placed on the left and right walls of the listening area. The surround loudspeakers should radiate sound in a nondirectional manner, allowing the listeners to hear only a diffused sound. Properly installed surround loudspeakers will provide ambience, and should not distract from the direct sound reproduced by the front loudspeakers.

HOME THX AUDIO SURROUND CHANNELS

Home THX circuits add additional processing to all the original Dolby Pro Logic decoded signals. The monaural surround signal is further processed into two separate spatially expanded left and right surround signals.

HOME THEATER AUDIO CHANNEL CONFIGURATION WITH DOLBY PRO LOGIC™ AND HOME THX AUDIO

There are specific Home THX Audio requirements for surround sound level calibration. This information is included in the manual section "McINTOSH HOME THEATER SURROUND SOUND VOLUME LEVEL CALIBRATION".

SUBWOOFER

Home THX Audio specifications require a subwoofer to be used in a home theater system. A subwoofer loudspeaker is designed to reproduce only the lowest audio frequencies, which are essentially non-directional. The C39 meets this requirement by combining the Left, Right and Center channel signals and feeding them through a filter that allows only the bass frequencies of 80Hz and lower to be fed to the subwoofer outputs. The non-directional sound characteristics of a subwoofer allow it to be placed in a wide range of room locations.

A well designed subwoofer will reproduce the low frequency music and sound effects present in today's action movie sound tracks with dramatic impact. Using a discretely placed subwoofer also allows the optional use of somewhat smaller and less obtrusive front loudspeakers.

Detailed information on Home Theater loudspeaker setup is covered in the manual enclosed with your McIntosh HT Series Home Theater loudspeakers.

FRONT PANEL CONTROLS, SWITCHES AND PUSHBUTTONS

The C39 can be remotely controlled. Most of the operating functions performed at the front panel, also can be done by the C39 Hand Held Remote Controller. The following information refers only to the front panel. Another section of this manual explains the operation of the C39 Hand Held Remote Controller.

The back cover of this manual folds out to show drawings of the front and rear panels of the C39. This will assist you in identifying and locating the front panel controls, switches, pushbuttons and the rear panel connectors and switches. The letters and numbers on the drawings refer to the information that follows.

A. BASS and TREBLE

Provides 12dB boost and cut, with neutral flat response at the center detent position. The Bass and Treble controls affect the LEFT and RIGHT Balanced Outputs, the LEFT FRONT, CENTER, RIGHT FRONT and SUBWOOFer Unbalanced Outputs. These are all Area "A" Outputs. The corresponding channels of the 6 CHANNEL OUTPUT connector are also affected.

The VCR1, VCR2, TAPE 1, TAPE 2 and Area "B" Outputs are not affected by the Bass and Treble controls.

B. RECORD

Selects any of the 12 audio input program signals that will feed the TAPE 1, TAPE 2, VCR 1, VCR 2 and Area "B" Audio Outputs.

Area "B" must first be turned ON in Area "B", by a keypad or remote controller transmitting to an Area "B" sensor, before the Area "B" outputs will operate.

The audio signals for SATellite, TV, Laser Video, VCR1, VCR2 and V-AUX will have their corresponding video signals switched simultaneously. The selected video RECORD signals will appear at the MONitor B, VCR1 and VCR2 VIDEO Outputs. This allows the selected program signals to be fed to an external TV monitor, as well as to one or two VCR units for recording purposes.

All audio or video tape recording must be setup manually in Area "A". Prior to a recording session, always press the REC (Record) LOCK pushbutton to disable all remote sensors or keypads to avoid accidental recording disruption.

C. MODE (Selects the operating configuration)

MONO: All left and right channel signals are combined for Mono operation and fed to the LEFT FRONT, RIGHT FRONT, Balanced, Unbalanced and the corresponding 6 CHANNEL connector outputs. The combined Mono signals of 80Hz and lower are also fed to the SUBWOOFER Output.

The Unbalanced CENTER Output can be activated in MONO by setting the rear panel CENTER FILL Switch (25), to the ON position. This allows a Center channel loudspeaker to be used during MONO operation.

STEREO: Left channel signals are fed to the LEFT FRONT Unbalanced and the LEFT Balanced Outputs. Right channel signals are fed to the RIGHT FRONT Unbalanced and the RIGHT Balanced Outputs. The Left and Right signals at 80Hz and lower are combined and fed to the SUBWOOFER Output.

The Unbalanced CENTER Output, which contains the combined left and right channel signals can be activated by setting the rear panel CENTER FILL Switch (25), to the ON position. This allows a Center channel loudspeaker to be used during STEREO operation.

HALL: ENHANCES TWO CHANNEL AUDIO SIGNALS. Left channel signals are fed to the LEFT FRONT Unbalanced and LEFT Balanced Outputs. Right channel signals are fed to the RIGHT FRONT Unbalanced and RIGHT Balanced Outputs. The Left and Right signals of 80Hz and lower are combined and fed to the SUBWOOFER Output. The combined Left and Right audio signals are also fed to a Digital Processor, time delayed, and then fed to the LEFT SURround and RIGHT SURround Outputs. The time delay can be adjusted by the front panel DELAY (ms) Switch.

The Unbalanced CENTER Output can be activated in HALL mode by setting the rear panel CENTER FILL Switch (25), to the ON position. This allows a Center channel loudspeaker to be used in the HALL operating mode.

CINEMA 1, TO REPRODUCE DOLBY SURROUND, PRO LOGIC DECODED MOVIE SOUNDTRACKS:

Audio signals from a Dolby Surround encoded movie soundtrack are fed to the C39 Dolby Pro Logic processing and decoding circuits which produce the following outputs.

Left audio signals are fed to the LEFT FRONT Unbalanced and LEFT Balanced Outputs. Right audio signals are fed to the RIGHT FRONT Unbalanced and RIGHT Balanced Outputs. The Dolby Pro Logic processing circuits also decode the center channel signals which include dialog, and feed them to the Unbalanced CENTER Output. The Dolby Pro Logic processed monaural surround sound signals are fed to the LEFT Surround and RIGHT Surround outputs.

The Left, Right and Center signals of 80Hz and lower are combined by the C39 and fed to the SUBWOOFER Output.

The Dolby Pro Logic Indicator on the C39 front panel lights when the MODE Switch is in CINEMA 1 position.

Dolby Surround encoding is also used for MTS and satellite broadcasts as well as other audio-only program sources such as compact discs. Use the C39 CINEMA 1 mode with its Dolby Pro Logic processing to enjoy listening to these other program sources.

FRONT PANEL CONTROLS, SWITCHES AND PUSHBUTTONS

CINEMA 2, HOME THX AUDIO: TO REPRODUCE DOLBY SURROUND, PRO LOGIC DECODED MOVIE SOUNDTRACKS WITH HOME THX AUDIO ENHANCEMENT.

The CINEMA 2 or Home THX Audio mode of operation is possible only when the optional McIntosh THX-M Module has been installed in the C39.

The four Dolby Pro Logic processed output signals are fed to the Home THX Audio circuits in the THX-M module for further processing and enhancement which produce the following six outputs.

Left audio input signals are fed to the LEFT FRONT Unbalanced and LEFT Balanced Outputs. Right audio signals are fed to the RIGHT FRONT Unbalanced and RIGHT Balanced Outputs. The processing circuits also feed center channel signals which include dialog, to the Unbalanced CENTER Output. The Dolby Pro Logic decoded monaural surround signals are then further processed into separate spatially expanded left and right surround signals, which are fed to the LEFT Surround and RIGHT Surround Unbalanced outputs.

The Left Front, Center and Right Front signals of 80Hz and lower are also combined by the C39 and fed to the SUBWOOFER Output.

With the McIntosh THX-M Module installed in the C39, the front panel Home THX Audio Indicator lights when the MODE Switch is in CINEMA 2 position. The Dolby Pro Logic front panel indicator stays lit in both CINEMA 1 and CINEMA 2 mode.

All signals fed to the six unbalanced outputs also are fed to corresponding pins on the rear panel 6 CHANNEL OUTPUT connector.

D. DISPLAY WINDOW

1. The **Dolby Pro Logic™** indicator lights when the C39 is switched to CINEMA 1 or CINEMA 2 Mode.

2. The **Home THX Audio** indicator lights when the C39 is in CINEMA 2 Mode, and the optional THX-M Module is installed.

The optional McIntosh THX-M Module must be installed in the C39 for the Home THX Audio indicator to light.

3. The % (Percentage), **VOLUME** indicator always lights when the C39 is turned on and operating. The selected volume is indicated as a percentage of maximum, with numbers reading from 0 to 99. The indicator also shows the amount of volume level trim that is used for each channel during the surround level calibration procedure.

E. LISTEN

Selects any of the 12 audio input program signals that will feed the six Unbalanced outputs, the two Balanced outputs and the SIX CHANNEL OUTPUT connector. These are Area "A" signals. The audio signals for Satellite, TV, Laser Video, VCR1, VCR2 and V-AUX will have their corresponding Video signals switched simultaneously. The selected LISTEN video signals will appear at the MON A Video Outputs. You can select either audio only programs for listening, or audio/video programs for listening and viewing.

The VCR1, VCR2, TAPE 1 and TAPE 2 and Area "B" outputs are not affected by the LISTEN switch.

F. VOLUME

Adjusts the volume level of all six Unbalanced outputs, the two Balanced outputs and the 6 CHANNEL OUTPUT Connector. These are Area "A" outputs.

The VCR1, VCR2, TAPE 1, TAPE 2 and Area "B" Outputs are not affected by the front panel VOLUME Control.

G. LOUDNESS and BALANCE (Concentric Controls)

BALANCE control, (large outer knob): Adjusts the volume of the Left and Right channels relative to each other. The BALANCE control affects only the LEFT FRONT, RIGHT FRONT Unbalanced, LEFT and RIGHT Balanced, Area "A" Outputs and the six channel connector. The BALANCE Control is effective in all five modes of operation.

L, (Left): Turn the control to the left to accent the left channels by reducing the volume of the right channels.

R, (Right): Turn the control to the right to accent the right channels by reducing the volume of the left channels.

The VCR1, VCR2, TAPE 1, TAPE 2 and Area "B" Outputs are not affected by the BALANCE Control.

LOUDNESS control, (small inner knob): Provides frequency response contoured to compensate for the behavior of the human ear at softer listening levels. At the fully counterclockwise detent position, the frequency response is perfectly flat and the loudness circuit components are removed from the signal path. Turn the control clockwise to modify the frequency response in the correct proportion required for softer listening levels. The compensated frequency response is not affected by changes in the volume control settings. First adjust the VOLUME Control for the desired listening level, then adjust the LOUDNESS Control to the setting you personally prefer.

The LOUDNESS Control affects the LEFT FRONT, CENTER, RIGHT FRONT, SUBWOOFER Unbalanced, LEFT and RIGHT Balanced outputs and the corresponding outputs on the 6 CHANNEL Connector. These are Area "A" Outputs. The LOUDNESS Control is effective in all five modes of operation.

The VCR1, VCR2, TAPE 1, TAPE 2 and Area "B" Outputs are not affected by the LOUDNESS Control.

NOTE: The flat frequency response setting of the LOUDNESS Control is at the FULLY COUNTER CLOCKWISE position, not at the center or 12 o'clock position where the BALANCE Control is neutral.

H. SYS CAL, SYStem CALibrate, (SUR CAL)

Allows the volume level of all six channels to be accurately set using the built-in C39 noise generator. Calibration includes individual channel volume level adjustment or trimming which may be required due to room geometry or differences in amplifiers or speakers. The calibration can be done by cycling through the six channels automatically or manually, depending on the setting of the C39 rear panel SURROUND CALIBRATE switch. The chosen level calibration settings are then retained in the Control Center memory.

Surround sound calibration is possible in the HALL, CINEMA 1 and CINEMA 2 Modes.

Normal listening levels and surround calibration volume levels can be set as you desire for HALL or CINEMA 1 Modes. For CINEMA 2 or Home THX® Audio Mode, the requirements are more specific. Refer to the manual section "McINTOSH HOME THEATER SURROOUND SOUND VOLUME LEVEL CALIBRATION" for calibration procedures for both CINEMA 1 and CINEMA 2.

An LED lights above the SYS CAL, (SUR CAL), pushbutton during calibration operation.

FRONT PANEL CONTROLS, SWITCHES AND PUSHBUTTONS

I. SURR LEVEL, SURRound LEVEL, (SUR CAL), UP (▲) or DOWN (▼)

UP (▲) and DOWN (▼) pushbuttons adjust the volume level match of all six channels as described in the manual section "McINTOSH HOME THEATER SURROUND SOUND VOLUME LEVEL CALIBRATION".

J. SURR PROC (SURRound PROCessor)

Press the SURR PROC pushbutton if you wish to remove all signal processing functions in HALL, CINEMA 1 or CINEMA 2 modes, and return to normal STEREO mode. Press again to restore signal processing.

An LED above the SURR PROC pushbutton turns on to indicate when signal processing is active.

K. SENSOR

The Infrared sensor that accepts control signals from the C39 Hand Held Remote Controller.

L. CAMCORDER (S VIDEO, L and R AUDIO, Behind Door)

A Camcorder with audio and either S or standard video outputs can be connected to the C39 on the front panel for convenient audio/video playback. To access the Camcorder connections, press the ACCESS pushbutton to open the motor driven door. When the door opens, the rear panel V-AUX VIDEO inputs are automatically switched to the front panel Camcorder inputs. The rear panel V-AUX AUDIO inputs are automatically switched to the front panel Audio jacks when audio cables are inserted into the Camcorder jacks. Press ACCESS again to close the door.

M. PHONES (Behind Door)

Plug in a pair of low impedance dynamic headphones to this jack for two channel stereo headphone listening. The headphone outputs are configured so you always hear the full two channel stereo information which maintains the phantom center channel, even when the surround sound signals are feeding the six loudspeakers in CINEMA 1 or CINEMA 2 modes. Access the PHONES jack by pressing the ACCESS pushbutton to open the motor driven door.

N. DELAY

This switch allows you to change the time delay of the signals in the surround sound channels. The numbers indicate the time delay in milliseconds when the C39 is in CINEMA 1 (Dolby Pro Logic), or CINEMA 2 (Home THX Audio) operating modes. The HALL mode of operation has slightly longer delay times. Refer to the chart below for the exact delay times for each mode.

The CENTER, 20ms position, is the recommended initial setting for all operating modes using surround sound.

The longer delay times simulate the listening effect of a larger listening room or hall. The shorter delay times simulate a smaller or more intimate listening area. You may wish to experiment with different delay settings based on your personal preferences.

CINEMA 1 and CINEMA 2 MODE DELAY TIMES

The delay times for each switch setting indicated on the front panel are rounded to 1ms.

FRONT PANEL INDICATION	ACTUAL TIME DELAY IN MILLISECONDS
12	12.2ms
16	16.4ms
20 (Recommended Setting)	20.5ms
24	24.6ms
28	28.7ms

FRONT PANEL CONTROLS, SWITCHES AND PUSHBUTTONS

HALL MODE DELAY TIMES

In the HALL operating mode, the time delays are slightly longer than the panel indications. Set the delay according to your personal preference. The shorter delay times simulate a smaller room, while the longer delays simulate a large room or concert hall.

FRONT PANEL INDICATION	ACTUAL TIME DELAY IN MILLISECONDS
12	16.4ms
16	32.8ms
20 (Recommended Setting)	49.2ms
24	65.1ms
28	81.9ms

O. ACCESS

Press the ACCESS pushbutton to open the motor driven door over the Camcorder and Headphone connectors. As soon as the door opens, the rear panel V-AUX VIDEO inputs are switched to the front panel Camcorder Video inputs. The V-AUX AUDIO inputs are automatically switched to the front panel Audio inputs when audio cables are inserted into the Camcorder jacks. Press ACCESS again or turn the front panel VOLUME control to close the door.

P. REC LOCK (RECORD LOCK)

Press this pushbutton to disable any remote AREA "B" sensors or keypads. This avoids the possibility of someone accidentally sending a control signal from AREA "B" that would disrupt a recording process set up in Area "A". A red LED above the REC LOCK pushbutton lights to indicate AREA "B" and its sensors are turned off.

Q. MUTE

Press MUTE to silence all six audio output channels in Area "A". A Red LED above the MUTE pushbutton will blink on and off to indicate that the signals are muted. Press MUTE again or turn the front panel VOLUME control to restore normal audio operation. The front panel MUTE does not affect the TAPE or Area "B" Outputs.

Mute Area "B" by using the hand held remote controller transmitting to a wall sensor or a keypad in Area "B". A red LED will blink on and off in either the wall sensor or a keypad in Area "B" to indicate the area is muted.

R. POWER

Press POWER to turn on the C39 system. The front panel will illuminate and show the program signals and operating modes selected in Area "A". Only the Area A outputs and Area "A" power amplifier will turn on. The Area "A" power amplifier AC power cord must be connected to, or controlled by, the C39 rear panel Area "A" AC outlet.

Area "B" Outputs and the dedicated Area "B" power amplifier can be turned on only in Area "B" by a keypad or remote controller transmitting to an Area "B" sensor.

The Area "B" power amplifier AC power cord must be connected to, or controlled by, the C39 rear panel Area "B" AC outlet.

The descriptions and functions of the C39 Remote Controller pushbuttons refer to the numbers on the drawing.

1. Select any of the 12 Audio and Audio/Video LISTEN program signals in Area "A". Select any of the same 12 Audio and Audio/Video program signals in Area "B". The selected Area "B" signals are also the RECORD program signals.

C39 HAND HELD REMOTE CONTROLLER

C39 HAND HELD REMOTE CONTROLLER

2. Select Tuner station presets or relay operation on the HC-1 Home Controller. First press the HOME pushbutton (4) and then the desired pushbuttons 0 through 9 (2) within five seconds to activate the relays on the HC-1.

The number pushbuttons also function with the RCT-1 Remote Control Translator, when it is programmed to allow the C39 to remotely control other brand products.

3. Select CD Player, CD Changer or tape recorder functions.

Using a McIntosh a **SINGLE DISC CD PLAYER**, STOP, BACK TRACK (◀◀), NEXT TRACK (▶▶) and PLAY functions can be performed.

Using a McIntosh **CD CHANGER**, STOP, BACK TRACK (◀◀), NEXT TRACK (▶▶) and PLAY functions can be performed while a disc is playing.

When the CD changer is in the **STOP** position, BACK TRACK (◀◀) selects the SINGLE DISC and NEXT TRACK (▶▶) selects which of the other six discs you wish to play. After pressing STOP, the first time you press NEXT (▶▶), disc number 1 is selected. Press again as desired to select discs 2 through 6.

FOR EXAMPLE: To select disc number 6 from the single disc play mode, press STOP and then NEXT (▶▶) six times. To select disc number 2, press STOP and then press NEXT (▶▶) twice. To select the disc in the SINGLE disc slot, press STOP and then press BACK (◀◀) once.

4. Press HOME to operate the HC-1 Home Controller functions. Within five seconds press a pushbutton number from 0 to 9 to control the desired relays on the HC-1,

5. Press SYS OFF to turn the entire C39 system off from **either** Area "A" or Area "B" after the SYS OFF is activated.

6. Press POWER to turn on the main system in Area "A". Press in Area "B" to turn on just Area "B" Outputs and power amplifier. Each time Area "B" is turned on, the TUNER input is automatically selected at a volume level 50dB below maximum. The Area "A" power amplifier and dedicated Area "B" power amplifier AC power cords must be connected to or controlled by their respective C39 rear panel Area "A" and Area "B" AC outlets.

7. Select Tuner functions of AM, FM or SEEK. When an RCT-1 Translator is being used to control a TV set, the SEEK UP or DOWN pushbuttons can be used to change TV channels.

8. First press TUNER and then press REVIEW to start the automatic audition of each of the preset stations stored in tuner memory of a compatible McIntosh tuner. Press REVIEW again to stop on the desired preset. Cancel the REVIEW process by pressing REVIEW a second time, or pressing any other Tuner function pushbutton.

9. E (ENTER or EXTRA) is used for controlling functions of an accessory component when an RCT-1 Remote Control Translator is being used.

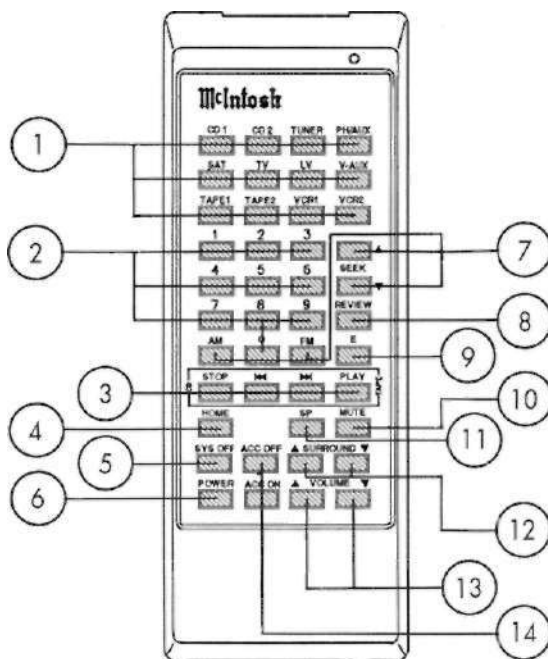

C39 HAND HELD REMOTE CONTROLLER

10. Press MUTE to mute the audio signals separately in either Area "A" or "B". Area "A" muting is indicated by a Red LED above the MUTE pushbutton that blinks on and off. To unmute Area "A", press MUTE a second time, press an UP (▲) or DOWN (▼) VOLUME pushbutton or turn the front panel VOLUME control.

11. SP (Surround Processor) pushbutton switches Area "A" surround signal processing functions IN or OUT, in HALL, CINEMA 1 or CINEMA 2 modes. When signal processing is switched OUT, the C39 is in normal STEREO operating mode.

An LED above the front panel SURR PROC pushbutton turns on to indicate signal processing is active.

12. Press either the UP (▲) or DOWN (▼) SURROUND push button to calibrate individual channel level balance during surround sound calibration procedure on all six channels. You can also raise or lower the surround sound levels during normal operation with these pushbuttons.

13. Press UP VOLUME (▲) to raise the listening volume and DOWN VOLUME (▼) to lower the listening volume. All six channels are affected.

The VCR1, VCR2, TAPE1, and TAPE2 Outputs are not affected by the remote volume pushbuttons.

14. Press ACC (ACCESSORY) OFF or ACC ON to control the AC Power of an accessory component that is being used in combination with an RCT-1 Remote Control Translator.

HOW TO INSTALL BATTERIES IN THE C39 HAND HELD REMOTE CONTROLLER

Slide open the battery compartment. Insert two type AA batteries into the compartment, making sure to observe the battery polarities indicated in the battery compartment.

When the batteries are nearing exhaustion, the effective range of the remote controller decreases, and MAY even fail to operate. In this case, replace both batteries with fresh ones.

NOTE:

1. Do not mix old and new batteries. Use ONLY batteries that are new.
2. Make sure both batteries are of the same type and identical.
3. To prevent damage caused by possible battery leakage, remove the batteries from the remote controller if it is not going to be used for an extended period of time.
4. Never dismantle batteries or dispose of them in a fire, as they may explode. Dispose of old batteries in an approved method for proper safety.

Use high quality cables to interconnect the audio and video accessory equipment used with your C39 Control Center. This will ensure the best possible performance from your McIntosh Audio/Video Home Theater and Stereo system. Your McIntosh dealer can advise you on the types and lengths of cables best suited for your particular installation.

ALL SIGNALS FED TO THE SIX UNBALANCED OUTPUTS ALSO APPEAR AT THE C39 REAR PANEL 6 CHANNEL OUTPUT CONNECTOR AND ARE FED THROUGH A 25 CONDUCTOR SUBMINIATURE "D" MALE-TO-FEMALE COMPUTER TYPE CABLE TO A MATCHING CONNECTOR ON A MCINTOSH MC7106 SIX CHANNEL POWER AMPLIFIER.

THE REAR PANEL AND HOW TO MAKE CONNECTIONS

**THE
REAR PANEL
AND
HOW TO MAKE
CONNECTIONS**

THE CHANNEL ALLOCATION IS AS FOLLOWS:

CHANNEL 1	Center Front
CHANNEL 2	Left Surround
CHANNEL 3	Left Front
CHANNEL 4	Right Front
CHANNEL 5	Subwoofer
CHANNEL 6	Right Surround

1. SUR (SURround)

Connect a pair of cables from the SURround AUDIO OUTPUT jacks to the inputs of the power amplifier channels which will feed left and right surround sound loudspeakers.

2. CENTER

Connect a cable from the CENTER AUDIO OUTPUT jack to the amplifier channel that will feed a center front loudspeaker.

3. SUBWOOF (SUBWOOFer)

Connect a cable from the SUBWOOFer AUDIO OUTPUT jack to the amplifier channel feeding a subwoofer loudspeaker. This output includes only audio frequencies of 80Hz and lower.

4. FRONT

Connect a pair of cables from the FRONT AUDIO OUTPUT jacks to the left and right front amplifiers. Use these outputs if you are operating the C39 as a conventional two channel stereo control center.

The same signals that feed the FRONT AUDIO OUTPUT jacks also feed the BALANCED OUTPUTS, (See No. 18.)

5. VCR1, VCR2

Connect cables from the C39, VCR1 and VCR2 AUDIO OUTPUT jacks to the high level audio inputs of two VCR units. These connections allow you to record the audio portion of ANY input selected by the RECORD switch.

6. TAPE 1, TAPE 2

Connect cables from the C39, VCR1 and VCR2 AUDIO OUTPUT jacks to the high level inputs of two audio tape recorders. These connections allow you to record the audio portion of ANY input selected by the RECORD switch.

7. RECORD PROCESSOR, FROM and TO

An external signal processor can be added to the C39 which will affect audio recording signals only at the VCR1, VCR2, TAPE 1 and TAPE 2 audio outputs. The PROCESSOR FROM jacks have built-in switching contacts that allow normal signals to pass through when no cables are connected. When an external signal processor is properly connected, the program signals will feed to the processor from the C39 PROCESSOR TO jacks, and return to the C39 at the PROCESSOR FROM jacks.

Connect a pair of cables from the external processor Outputs to the C39 PROCESSOR FROM jacks. Connect another pair of cables from the external processor Inputs to the C39 PROCESSOR TO jacks.

WHEN AN EXTERNAL SIGNAL PROCESSOR IS CONNECTED TO THE C39 RECORD PROCESSOR JACKS, THE PROCESSOR MUST BE TURNED ON AND OPERATING, OR

IN BYPASS MODE, FOR THE PROGRAM SIGNALS TO BE FED TO THE VCR, TAPE OR AREA "B" AUDIO OUTPUTS.

8. VCR1, 2 and V-AUX (Auxiliary)

Connect cables from the Audio Outputs of VCR units or other similar Audio/Video accessories to these three AUDIO INPUTS.

9. LV (Laser Video)

Connect a pair of cables from a Laser Video Disc player Audio Outputs to the LV AUDIO INPUTS.

10. TV

Connect a pair of cables from the Audio Outputs of a TV set, TV Monitor or TV Tuner to the TV INPUTS.

11. SAT (SATellite)

Connect a pair of cables from the Audio Outputs of a Satellite TV Tuner or Receiver to the SAT INPUTS.

12. TAPE1 and TAPE2

Connect a pair of cables from the Outputs of two audio tape recorders to the TAPE1 and TAPE2 INPUTS.

13. TUNER

Connect a pair of cables from the outputs of an AM/FM Stereo Tuner to the TUNER INPUTS.

14. CD1, CD2

Connect a pair of cables from the output of two CD players to the CD1 and CD2 INPUTS. For example, CD1 Inputs could be used for a single disc player, and CD2 Inputs for a CD changer.

When the C39 is used with the CR 10 Remote Control System, only the CD2 input will function with the CR 10.

15 and 16. AUX (Auxiliary) and PH (PHono)

Both the PHono and Auxiliary inputs are selected by the same position on the front panel LISTEN and RECORD selector switches. Either the PHono or Auxiliary inputs can be used, but not both at the same time. When a pair of cables is connected to the Auxiliary input jacks, the PHono section is automatically bypassed.

Auxiliary: Connect a pair of cables from the outputs of an accessory component to the AUX INPUTS.

To use the PHono inputs, FIRST remove any cables connected to the AUX inputs.

PHono: Connect a pair of cables from a record player with a moving magnet phono cartridge to the PH INPUTS.

AUX: Connect a pair of cables from the high level outputs of an accessory component to the AUX inputs.

17. GND (Ground)

If the phono player being used has a separate ground lead, connect it to the GND terminal.

18. L and R BALANCED OUTPUTS

Connect cables with XLR type Balanced Connectors from the C39 L (Left) and R (Right) BALANCED OUTPUT jacks to the balanced input jacks of the power amplifier. Signals at the

THE REAR PANEL AND HOW TO MAKE CONNECTIONS

BALANCED jacks are present whenever the C39 Area "A" is on and operating, and are the same signals as at the Unbalanced Left Front and Right Front Outputs.

Using balanced connectors and cables can reduce noise and interference by as much as 40dB. This extra noise reduction can be a significant improvement, especially if the cables are quite long.

If two separate mono power amplifiers are used with the C39 to reproduce the Left and Right Front signals, balanced cables can eliminate the possibility of hum pickup.

If cable lengths between the C39 and the power amplifiers are one meter or less, you may find high quality unbalanced cables to be satisfactory.

Balanced Jack Pin Configuration:

Pin 1. System Ground

Pin 2. + Output

Pin 3. - Output

19. ANT/CABLE, TV and MODULATOR

ANT/CABLE: Connect a coaxial cable from a TV Antenna or Cable Output to the ANT/CABLE Coaxial connector.

TV: Connect a coaxial cable from the C39 TV coaxial output to the coaxial antenna input of a TV receiver being used as a monitor. Whenever the C39 is turned OFF, the RF signals feed from the ANT/CABLE connector directly to the TV connector for normal TV reception.

When the C39 is turned on, and any of the VIDEO signal sources are selected, the RF signal from the ANT/CABLE is turned off and the TV will receive audio/video signals selected by the C39. The C39 MODULATOR feeds only mono audio signals to the TV

CHANNEL 3 - 4: Set this switch to select which channel on the TV you would like to receive the audio/video signals.

INPUT A-B: Switch to position "A" for audio/video signals selected by the front panel LISTEN "A" selector switch, or to position "B" for audio/video signals selected by the RECORD "B" switch. In order to receive audio/video signals selected by the RECORD "B" switch, Area "B" must first be turned ON in Area "B". When Area "B" is turned off, the RF signals from the ANT/CABLE pass on through to the TV set when the INPUT A-B switch is in the "B" position.

TV AUDIO: Adjust the TV AUDIO volume control for the desired audio level from the TV.

20. AC OUTLETS (Total of Three)

The SWITCHED AC outlet turns on whenever the C39 is turned on in either Area "A" or Area "B", and can be used to power any audio or video accessory used in the system.

AREA "A" PWR AMP outlet supplies AC to the power amplifier connected for use in the Main, or Area "A", whenever the C39 is turned on.

AREA "B" PWR AMP supplies AC to the power amplifier connected to the Area "B" Outputs.

The Area "B" Outputs and dedicated power amplifier can only be turned on by the C39 Remote Controller or WK-1 keypad in Area "B".

To expand the number and current capability of any of the three AC outlets, a power control relay such as the McIntosh R612 or PC-2 can be used.

TOTAL CURRENT CAPACITY OF ALL C39 REAR PANEL AC OUTLETS IS 1400 WATTS

21. POWER CONTROL

This connector supplies a 5 volt DC Logic 1 control signal to feed to a Power Control Input on a McIntosh MC7106 Power Amplifier or other compatible accessory to turn its AC power on and off.

The interconnect cable from the C39 POWER CONTROL jack to the MC7106 POWER CONTROL IN jack uses single conductor shielded wire with 1/8" mini phone plugs. Connections are to the sleeve and tip of the plug.

22. SURROUND CALIBRATE, (AUTO, MANual)

Set this switch to the AUTOMATIC position for the built-in noise generator to automatically switch its signal to each of the six channels in sequence, for surround volume level calibration and trim procedure required for HALL, CINEMA 1 and CINEMA 2 operating modes.

Set the switch to the MANUAL position for manually switching the built-in noise generator to each of the six channels.

Press the SYS CAL, (SUR CAL), pushbutton to start the calibration process in either Manual or Auto channel cycling mode.

Refer to the manual section "McINTOSH HOME THEATER SURROUND SOUND VOLUME LEVEL CALIBRATION" for detailed information on the surround level calibration procedure.

23. AREA B OUTput, (L and R)

Connect a pair of cables from the AREA "B", L (Left) and R (Right) OUTputs to the inputs of the dedicated power amplifier that is connected to the loudspeakers in Area "B".

Area "B" must first be turned ON in area "B", by a keypad or remote controller transmitting to an Area "B" sensor, before the Area "B" outputs will operate. Each time Area "B" is turned on, the TUNER input is automatically selected at a volume level 50dB below maximum.

24. CENTER SPEAKER, (NONE, SMALL and LARGE THX)

The CENTER SPEAKER Switch is effective only in the CINEMA 1 and CINEMA 2 modes.

NONE: Set the CENTER SPEAKER SWITCH to the NONE position when no center speaker is being used. All the Left, Right and Center signals are then sent to the Left and Right front channel loudspeakers to maintain the Phantom Center Channel effect.

SMALL: Set the switch to the SMALL position when a small compact speaker is used for Center channel reproduction. This switch setting includes a low pass filter that allows only decoded center channel frequencies above 100Hz to be fed to the small center speaker. All Center low frequencies below 100Hz are then fed to the respective Left and Right Front loudspeakers.

LARGE (THX): Set the switch to the LARGE position when a full size, full range speaker is used for the Center channel. The switch must be in this position for Home THX Audio (CINEMA 2) operating mode.

25. CENTER FILL, (ON, OFF)

Set the switch to ON to activate the Center channel output when using the MONO, STEREO or HALL modes of operation. The center channel outputs in this configuration are the Left and Right channel stereo signals combined. This switch has no effect when using CINEMA 1 or cinema 2 modes of operation.

26. VIDEO OUTPUTS, (MONitor A, MONitor B, VCR1 and VCR2), S and Standard

MONitor A: Connect cables from either the S or Standard MONitor A Video output to the Video input on a TV monitor for video signals selected by the LISTEN, Area "A" Switch. The corresponding audio signals will be switched simultaneously.

MONitor B: Connect cables from either the S or Standard MONitor B Video Output to the Video input on a TV monitor for video signals selected by the RECORD Area "B" Switch. The

THE REAR PANEL AND HOW TO MAKE CONNECTIONS

corresponding audio signals will be switched simultaneously.

VCR1: Connect cables from either the S or Standard VCR1 Video Output to the video inputs of a VCR.

VCR2: Connect cables from either the S or Standard VCR2 Video Output to the video inputs of a second VCR.

Use either S or Standard Video connectors for all inputs and outputs. Do not mix connector types.

27. SUB WOOFER

This switch turns the subwoofer channel on or off in MONO, STEREO and HALL operating model. The subwoofer always operates in CINEMA 1 and CINEMA 2 modes, regardless of this switch setting.

28. HIGH PASS FILTERS

Set the switch to ON to filter all low frequencies below 80Hz from the Left Front, Center and Right Front speakers. This mode of operation is preferred when all three front speakers are small and compact. A Subwoofer will then be necessary to handle all bass frequencies of 80Hz and lower. Set the switch to OFF when full range front speakers are used. The HIGH PASS FILTERS switch, functions in all operating modes.

29. 6 CHANNEL OUTPUT

This connector accepts a 25 conductor shielded subminiature "D" male-to-female computer type cable that feeds all six program signals and the AC power control signal to the matching 6 channel (THX) connector on the rear panel of a McIntosh MC7106 Six channel power amplifier. A single cable connection between a C39 and MC7106 makes an easy and convenient installation for a McIntosh Home Theater system.

30. DATA PORTS

The 14 DATA PORTS provide data signals to be fed to compatible audio and video accessories. This allows you to control the accessory components with their own remote controllers transmitting to a C39 sensor.

The HOME DATA port is provided for connecting to the HC-1 Home Controller. This allows you to control accessories such as lights or viewing screen motors.

The SUM DATA port is used for connecting to the McIntosh Model RCT-1 Remote Control Translator. Any IR signal transmitted to a CR39 sensor results in data signals at this port. The RCT-1 is a learning device and will allow the C39 to remotely control most major brands of accessory components.

All cables connected from the DATA ports use shielded wire with 1/8" mini phone plugs. Connections are to the sleeve and tip of the plug.

Use either S or Standard Video connectors for all inputs and outputs. Do not mix connector types.

31. EXTERNAL SENSORS (AREA "A" and AREA "B")

Connect a coaxial cable from the AREA "A" EXTERNAL coaxial connector to an R649 Wall IR Sensor or WK-1 Keypad. This allows the C39 Remote Controller to send control signals to the C39 for Area "A" functions without aiming it at the C39 front panel. An example would be if the C39 were installed behind a cabinet door that would block the front panel sensor.

Connect a coaxial cable from the AREA "B" EXTERNAL SENSOR coaxial connector to an R649 Wall IR sensor or a WK-1 Keypad installed in the remote Area "B". This allows you to turn on Area "B" and select all the available system operating modes and program selec-

tions in Area "B". Area "B" must have its own dedicated power amplifier and speakers.

All coaxial connections use either RG59U or RG6 coaxial cable. Up to four Keypads or Sensors can be connected in parallel on each coaxial cable.

32. TUNER CONTROL

Connect a McIntosh Model W102 Tuner Control cable from the TUNER CONTROL connector to a connector on a compatible McIntosh tuner. This allows you to select and control tuner operating functions with the C39 hand held remote controller transmitting to a C39 sensor.

33. VIDEO INPUTS (SAT, TV, LV, VCR1, VCR2, and V-AUX, (S or Standard)

Connect coaxial cables from the video outputs of six separate video accessories to the appropriate video inputs. These six video inputs can be selected by either the LISTEN, Area "A" switch, or the RECORD, Area "B" switch. The corresponding audio signals are also selected simultaneously.

34. CD1/CD2 CONTROL

Connect a McIntosh Model W101 CD Control cable from the CD1 or CD2 CONTROL socket to a matching connector socket on a McIntosh CD player or changer. This allows you to control CD player functions with the C39 hand held remote controller transmitting to a C39 sensor. You could use CD1 for a single play CD player and CD2 for a CD changer.

35. TO MULTI-ROOM CONTROLLER

Connect a 25 conductor shielded subminiature "D" male-to-male computer type cable from the C39 TO MULTI-ROOM CONNECTOR to the matching connector on a McIntosh CR10 Remote Control System. With a CR10 connected, as many as four additional remote areas can be controlled. CD2, TUNER, TAPE 1, TAPE 2 and PH/AUX can be used by the CR10. All audio signals selected by the C39 LISTEN, Area "A" Selector Switch, are fed to the VIDEO inputs on the CR10.

A Home Theater combines the newest high fidelity surround sound audio concepts with the high quality video reproduction of the latest big screen TV sets and monitors. All the excitement of the special audio and video effects of today's action movies are now possible in your own home using a laser video disc player or VCR as a source.

All movies produced by major film companies have Dolby Stereo sound tracks. When they reach you via home video sources, the Dolby Surround encoding remains intact. Dolby Pro Logic relies on the same decoding technology as the professional cinema processors to decode the movie soundtracks that are found on video. The decoding process results in four separate soundtracks which are Left Front, Center, Right Front, and Surround. The Dolby Pro Logic decoded surround signals are monaural, but are reproduced by a non-directional loudspeaker on each side of the listening area to help diffuse the sound. The Dolby Surround concept is the heart of the Home Theater audio and video experience.

Lucasfilm Ltd. has developed a process for enhancing the reproduction of Dolby Surround sound tracks by adding additional signal processing to all the decoded sound tracks. This process is called Home THX Audio.

To experience the maximum pleasure from your McIntosh Home Theater System, the electronics and loudspeakers should be set up as closely as possible to the recommended

THE REAR PANEL AND HOW TO MAKE CONNECTIONS

HOW TO SETUP YOUR MCINTOSH HOME THEATER

HOW TO SET UP YOUR McINTOSH HOME THEATER

configurations. You may find it convenient to take advantage of the technical knowledge and experience of your McIntosh dealer to assist you in the setup procedure.

Reproducing Dolby Surround movie soundtracks with Dolby Pro Logic decoding requires a specific selection and location of loudspeakers. If you are using the optional THX-M module in your C39 for Home THX Audio processing, the requirements are even more specific.

McIntosh has introduced the HT Home Theater line of loudspeakers specifically designed for home theater use. These loudspeakers include models for Left Front, Center and Right Front, Surround Sound and a Subwoofer. The McIntosh HT loudspeakers are licensed for Home THX® Audio, and are ideal for reproducing Dolby Surround encoded movie soundtracks using Dolby Pro Logic decoding as well as Home THX® Audio processing enhancement. These loudspeakers also reproduce normal stereo music sources such as a compact disc with outstanding fidelity.

McIntosh is also manufacturing the Model MC7106, six channel power amplifier, specifically designed for Home Theater use. The MC7106 is also licensed for Home THX Audio and includes a convenient 25 conductor THX connector that accommodates a computer type cable to receive all six audio channels and AC power control from a matching connector on a C39 Control Center.

Dolby Pro Logic decoding produces four specific channels of audio information from a Dolby Surround encoded soundtrack. These channels include Left Front, Center, Right Front and Surround sound.

The front left and right loudspeakers provide the fundamental two channel stereo music and sound. The center channel is called the dialog channel since it also reproduces soundtrack dialog information. A center channel greatly increases the intelligibility of spoken dialog.

The three front loudspeakers should have wide horizontal sound dispersion to allow the effective area for audience participation to be spread as wide as possible in the home theater room. The vertical acoustic dispersion of the front speakers should be restricted to avoid floor and ceiling reflections that could interfere with the indirect reflected surround sounds.

The Dolby Pro Logic decoded surround sound signal is mono, but requires two separate loudspeakers. One is mounted on the left wall of the listening area and the other on the right wall. They should be approximately at or slightly above ear height. For the correct ambience effect, surround sound must be non directional and reflected from the room wall surfaces rather than directly from the loudspeakers.

The addition of a subwoofer can greatly enhance the enjoyment of your home theater. A subwoofer can reproduce the exciting low frequency music and sound effects of today's action movies with a dramatic impact. Since a subwoofer is inherently non directional, it can be placed in a variety of room locations. A good subwoofer also allows the optional use of smaller and less conspicuous loudspeakers in the front and center locations.

Home THX Audio specifies that a subwoofer be used. The C39 includes the required circuits to feed the correct bass signals of 80Hz and lower to the output that feeds the subwoofer power amplifier.

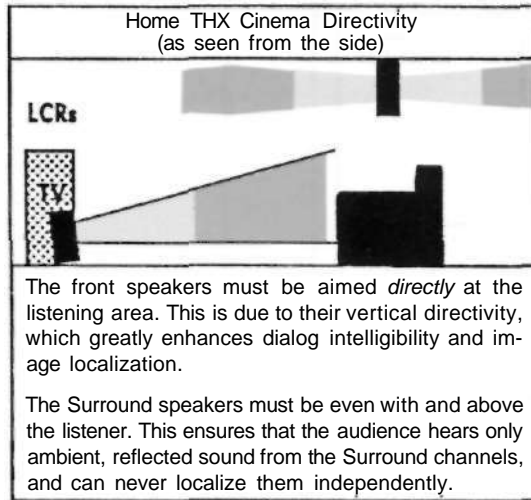
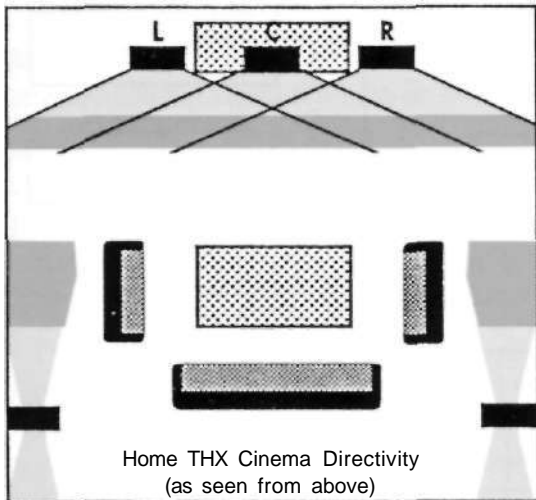

These drawings, courtesy of Lucasfilm Ltd., show a typical Home Theater layout.

HOME THEATER LAYOUT

HOME THEATER HOOK-UP

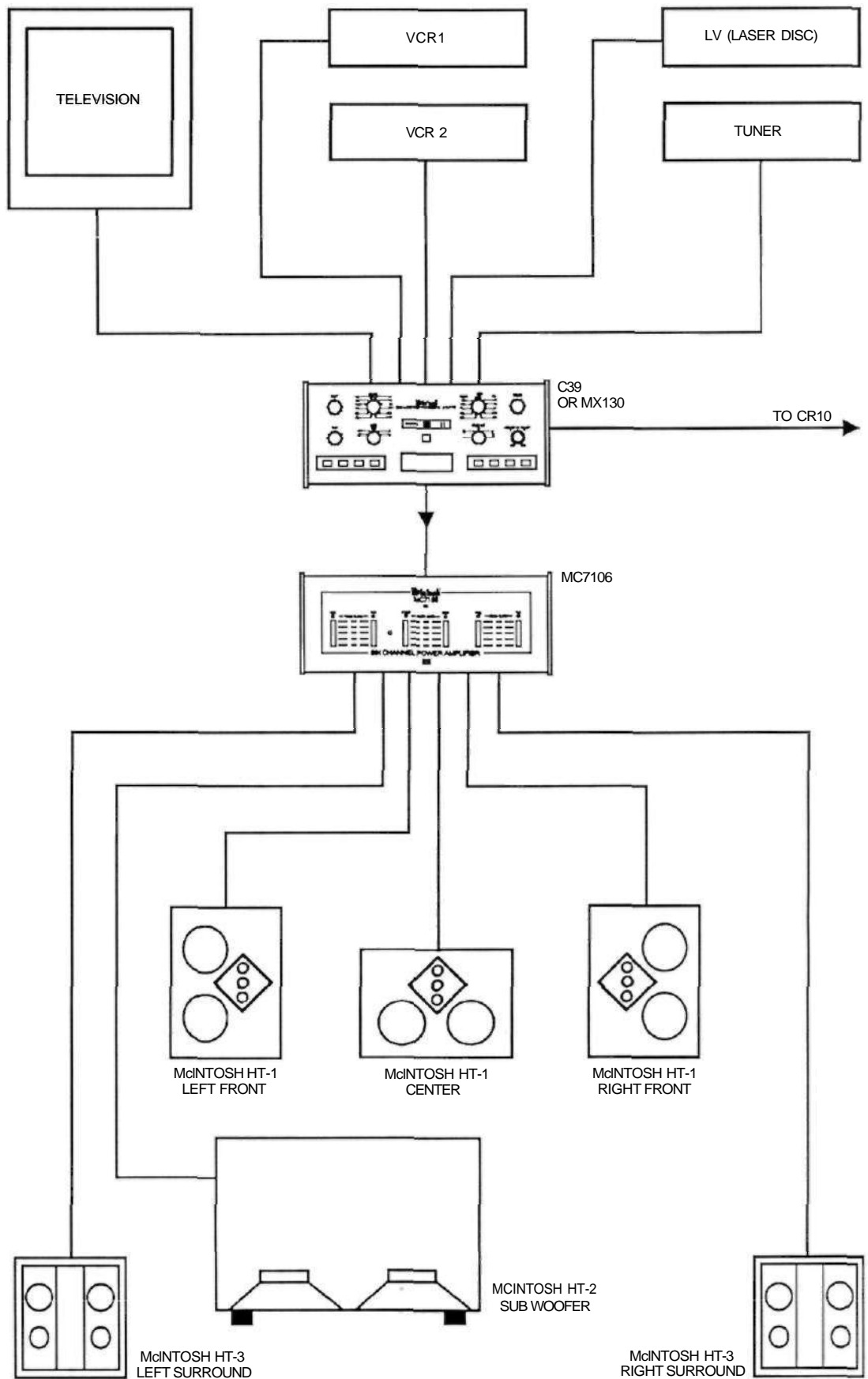

The McIntosh C39 has a convenient built-in Noise generator to allow trimming volume levels for each of the six channels. This process is described as Surround Sound Calibration. These selected volume levels are then retained in the C39 Control Center memory.

MANUAL CHANNEL CYCLING FOR CINEMA 1 DOLBY PRO LOGIC SURROUND SOUND LEVEL CALIBRATION

1. Set the MODE Switch to CINEMA 1.
2. Set the C39 VOLUME control to a level between 30% \pm 10%.
3. Set the rear panel SURROUND CALIBRATE Switch to MANUAL.

Press the SYS CAL, (SUR CAL), surround level calibration pushbutton. This starts the built-in noise generator and feeds it first to the LEFT FRONT channel to begin the level calibration process. Each further press of the SYS CAL, (SUR CAL) pushbutton feeds the noise generator signal to the other five channels in the following order: CENTER, RIGHT FRONT, RIGHT SURROUND, LEFT SURROUND and finally the SUBWOOFER.

Adjust the levels of each of the six individual channels with the front panel UP (\blacktriangle) or DOWN (\blacktriangledown) SURR LEVEL, (SUR CAL) pushbuttons until you achieve the level match you prefer in the listening area. It is recommended that all channel volume levels be as close to the same as possible.

Any changes made in channel calibration levels will be read as a TRIM number on the front panel % VOLUME indicator. Trim numbers will indicate + (Plus) or - (Minus) from 0 to 19. You may repeat the calibration process as many times as desired until you are satisfied with the results.

After the last channel, the Subwoofer, has been calibrated, press the SYS CAL, (SUR CAL), pushbutton again to exit the calibration mode.

You can also exit or cancel the manual calibration mode at any time by adjusting the front panel VOLUME control or pushing one of the remote controller VOLUME pushbuttons.

The dimensions and shape of the listening room can affect bass frequencies that are reproduced by a subwoofer. You may have to experiment with different locations for the subwoofer until you find one that works best in your room.

(For future reference, list the final calibration trim numbers in the space provided in this manual. If the C39 AC power cord is disconnected from the AC power line, or AC power is interrupted, the backup power supply will turn off and calibration memory will be lost. The calibration process must then be repeated.)

AUTOMATIC CHANNEL CYCLING FOR CINEMA 1 DOLBY PRO LOGIC SURROUND SOUND LEVEL CALIBRATION

1. Set the MODE Switch to CINEMA 1.
2. Set the C39 VOLUME control to a level between 30% \pm 10%.
3. Set the rear panel SURROUND CALIBRATE Switch to AUTO.
4. Press the SYS CAL, (SUR CAL), Surround level calibration pushbutton to start the automatic channel cycling calibration process. The built-in noise generator turns on and automatically feeds a signal for two seconds, to all six channels in the following order: LEFT FRONT, CENTER, RIGHT FRONT, RIGHT SURROUND, LEFT SURROUND and SUBWOOFER.

When either the UP (\blacktriangle) or DOWN (\blacktriangledown) SURR LEVEL, (SUR CAL) pushbutton is pressed during Automatic calibration, the channel switching function will temporarily stop to allow the level to be adjusted. One second after an UP (\blacktriangle) or DOWN (\blacktriangledown) SURR LEVEL, (SUR CAL) pushbutton has been pressed and then released, the automatic calibration switching will

McINTOSH HOME THEATER SURROUND SOUND VOLUME LEVEL CALIBRATION

continue to the next channel.

Adjust the levels of each of the six individual channels with the front panel UP (▲) or DOWN (▼) SURR LEVEL, (SUR CAL) pushbuttons until you achieve the level match you prefer in the listening area. It is recommended that all channel volume levels be as close to the same as possible.

A convenient method for surround volume level calibration in the Automatic mode, is to use the UP (▲) and DOWN (▼) SURROUND pushbuttons on the C39 Hand Held Remote Controller and operate it from a position located in the listening area at seated ear height. First press the SYS CAL, (SUR CAL) pushbutton on the C39 front panel to start the automatic channel cycling process.

Any changes made in channel calibration levels will be read as a TRIM number on the front panel % VOLUME indicator. Trim numbers will indicate + (Plus) or - (Minus) from 0 to 19. You may repeat the calibration process as many times as desired until you are satisfied with the results.

After all six channels have been calibrated, exit the automatic calibration mode by momentarily pressing either an UP (▲) or DOWN (▼) VOLUME pushbutton on the hand held Remote Controller, or by moving the front panel VOLUME control.

If the front panel VOLUME control is adjusted, or the remote controller VOLUME pushbuttons are pushed at any time during the calibration procedure, the calibration function will be canceled.

The dimensions and shape of the listening room can affect bass frequencies that are reproduced by a subwoofer. You may have to experiment with different locations for the subwoofer until you find one that works best in your room.

CINEMA 2 HOME THX AUDIO SURROUND SOUND LEVEL CALIBRATION

INTRODUCTION

The design of Home THX Audio amplifiers, preamplifiers and decoders includes careful control of the signal gains of each of the many circuits involved. Loudspeaker sensitivities, room size and listening distance will all contribute to the overall playback levels that are correct for the Home THX Audio process.

The built-in noise generator in the C39 allows trimming volume levels to the desired Home THX Audio requirements for each of the six channels. This process is described as Surround Sound Calibration. These selected volume levels are then retained in the Control Center memory.

After THX calibration is completed, your system, including a Home THX Audio licensed McIntosh MC7106 power amplifier and HT Series loudspeakers, will reproduce movie soundtracks from laser video discs at the same levels as heard by the movie producer who mixed the original sound tracks. Video tape audio levels may vary from those of laser video discs. You of course may change the overall volume levels to any settings you personally prefer. However, it is nice to know by using a Home THX Audio McIntosh Home Theater System, you can precisely duplicate the original sound levels specified by the people who produced the movie.

You can use other McIntosh power amplifiers that do not have an indicated Home THX Audio sensitivity setting, but you may have to make adjustments of the volume levels on the power amplifiers to achieve the desired results.

Accurate THX Volume calibration requires the use of a calibrated sound level meter positioned in the listening area at seated ear height. The meter is necessary to set the acoustic sound levels from each loudspeaker to 75dB as specified by the Home THX Audio standards.

MANUAL CHANNEL CYCLING FOR CINEMA 2 HOME THX AUDIO SURROUND LEVEL CALIBRATION

1. Set the C39 LISTEN Selector switch to the LV (Laser Video Disc Player) position.
2. Set the MODE Switch to CINEMA 2.
- 3. Adjust the C39 Volume control until the front panel Volume Level Indicator reads "44". This is the recommended Home THX Audio starting reference volume setting.**

This volume setting produces the required audio output when connected to a Home THX Audio licensed McIntosh MC7106 power amplifier driving McIntosh HT Series loudspeakers.

4. Set the rear panel SURROUND CALIBRATE switch to MANUAL.
5. Place the sound level meter in the primary listening area. Set the meter for flat response or C weighting, slow mode if available, and to an appropriate range for reading a sound pressure level of 75dB.
6. Press the SYS CAL, (SUR CAL) Surround calibration pushbutton. This activates the built-in noise generator and feeds it first to the LEFT FRONT channel to start the level calibration process. Each further press of the SYS CAL, (SUR CAL) pushbutton feeds the noise generator signal to the other five channels in the following order: CENTER, RIGHT FRONT, RIGHT SURROUND, LEFT SURROUND and finally the SUBWOOFER.

Adjust the levels of each of the six individual channels with the front panel UP (▲) or DOWN (▼) SURR LEVEL, (SUR CAL) pushbuttons until the sound level meter reads as close as possible to 75dB in the listening area.

Any changes made in channel calibration levels will be read as a TRIM number on the front panel % VOLUME indicator. Trim numbers will indicate + (Plus) or - (Minus) from 0 to 19. You may repeat the calibration process as many times as desired until you are satisfied with the results.

(For future reference, list the final calibration trim numbers in the space provided in this manual. If the C39 AC power cord is disconnected from the AC power line, or AC power is interrupted, the backup power supply will turn off and calibration memory will be lost. The calibration process must then be repeated.)

After the last channel, the Subwoofer, has been calibrated, press the SYS CAL, (SUR CAL) pushbutton again to exit the calibration mode.

You can also edit or cancel the manual calibration mode at any time by adjusting the front panel VOLUME control or pushing one of the remote controller VOLUME pushbuttons.

The dimensions and shape of the listening room can affect bass frequencies that are reproduced by a subwoofer. You may have to experiment with different locations for the subwoofer until you find one that works best in your room.

If the front panel VOLUME control is adjusted, or the remote controller VOLUME buttons are pushed at any time during the calibration procedure, the calibration function will be canceled.

**MCINTOSH
HOME THEATER
SURROUND
SOUND
VOLUME LEVEL
CALIBRATION**

SURROUND CALIBRATION LEVEL TRIM NUMBERS

LEFT FRONT: _____
CENTER: _____
RIGHT FRONT: _____
RIGHT SUR: _____
LEFT SUR: _____
SUBWOOFER: _____

LEFT FRONT: _____
CENTER: _____
RIGHT FRONT: _____
RIGHT SUR: _____
LEFT SUR: _____
SUBWOOFER: _____

AUTOMATIC CHANNEL CYCLING FOR CINEMA 2 HOME THX AUDIO SURROUND LEVEL CALIBRATION

The Automatic mode of Home THX Audio surround level calibration is not recommended since there may not be adequate time to get valid readings from the Sound Level Meter.

WHEN HOME THX AUDIO CINEMA 2 SURROUND CALIBRATION IS COMPLETED, A LASER VIDEODISC WILL PLAYBACK ITS MOVIE SOUNDTRACK IN YOUR MCINTOSH HOME THEATER SYSTEM AT THE SAME VOLUME LEVELS HEARD BY THE MOVIE PRODUCER WHO CREATED THE ORIGINAL SOUND TRACK. THIS WILL ALSO BE THE SAME LEVEL THAT YOU WILL HEAR IN A THX CALIBRATED MOVIE THEATER. VIDEO TAPE AUDIO LEVELS MAY VARY FROM THOSE OF A LASER VIDEODISC.

SURROUND LEVEL ADJUSTMENTS DURING LISTENING

During the actual listening and viewing process of a movie, you may wish to adjust the LEFT and RIGHT SURROUND sounds to volume levels different from those set during the calibration process. Do this by pressing the "UP" or "DOWN" SURROUND pushbuttons on the C39 Hand Held Remote Controller until you are satisfied with the results. These changes will remain as long as the C39 continues to operate.

When the C39 is turned off, the surround sound volume level changes you made during listening are canceled and all the original calibrated levels are restored.

If you wish to permanently recalibrate to different surround trim levels, turn off the C39. This will cancel the manual level changes and restore the volume levels set in memory during the most recent calibration process. Then turn the Control Center back on and repeat the calibration process to put your new preferred surround sound levels in memory.

Do not attempt to recalibrate surround levels after manual adjustment without first turning the C39 OFF and then ON, to restore the calibration memory to the original settings.

If you do not have a sound level meter available, you can calibrate all six channel levels by ear. You will certainly find the results enjoyable; however, you will not necessarily be listening at the same exciting volume level as intended by the movie producer.

FREQUENCY RESPONSE**MONO and STEREO MODES**

LEFT, CENTER and RIGHT FRONT channels +0, -0.5dB from 20Hz to 20,000Hz

HALL MODE

LEFT, CENTER and RIGHT FRONT channels, +0, -0.5dB from 20Hz to 20,000Hz.

LEFT and RIGHT SURROUND channels, +0, -3dB from 100Hz to 7000Hz.

DOLBY PRO-LOGIC MODE

LEFT, CENTER and RIGHT FRONT channels, ± 0.5 dB from 30Hz to 16,000Hz.

LEFT and RIGHT SURROUND channels ± 1 dB from 100Hz to 6300Hz, -3dB at 7000Hz

DOLBY PRO-LOGIC and THX MODES COMBINED

LEFT, CENTER and RIGHT FRONT channels, ± 0.5 dB from 30Hz to 1000Hz and ± 0.8 dB from 1000Hz to 16,000Hz.

LEFT and RIGHT SURROUND channels, ± 1 dB from 100Hz to 6300Hz and +1, -5dB to 8000Hz.

ALL MODES

SUBWOOFER channel low pass, 10Hz to a corner frequency of 80Hz with a 24dB per octave rolloff.

With the rear panel HIGH PASS switch in the ON position, the LEFT, CENTER and RIGHT FRONT channels include high pass filters with a 12dB per octave rolloff and a corner frequency of 80Hz.

RATED OUTPUT

2.5V at LEFT FRONT, CENTER, RIGHT FRONT, LEFT SURROUND, RIGHT SURROUND and SUBWOOFER unbalanced.

2.5V at LEFT and RIGHT FRONT Balanced.

OUTPUT IMPEDANCE

600 ohms at all outputs.

MAXIMUM VOLTAGE OUTPUT

6V RMS at all outputs.

TOTAL HARMONIC DISTORTION**MONO, STEREO and HALL MODES**

LEFT, CENTER and RIGHT FRONT channels, 0.005% from 20Hz to 20,000Hz.

(HALL MODE, only) LEFT and RIGHT SURROUND channels, 0.01 % from 125Hz to 7000Hz.

DOLBY PRO-LOGIC and THX MODES

LEFT, CENTER and RIGHT FRONT channels, 0.01% from 80Hz to 16,000Hz

LEFT and RIGHT SURROUND channels, 0.1% from 125Hz to 7000Hz.

SENSITIVITY

PHONO: 5.0mV for 2.5V output, (1.0mV IHF).

HIGH LEVEL: 500mV for 2.5V output, (100mV IHF).

DOLBY LEVEL: 200mV input.

SPECIFICATIONS

SIGNAL TO NOISE RATIO A-WEIGHTED

MONO, STEREO and HALL MODES

LEFT, CENTER and RIGHT FRONT channels,
PHONO: 90dB below 10mV input, (84dDB IHF).
HIGH LEVEL: 100dB below rated output (95dB IHF).

DOLBY PRO-LOGIC and THX MODES

All outputs greater than 70dB below reference level.

MAXIMUM INPUT SIGNAL

PHONO: 60mV.
HIGH LEVEL: 5V MONO and STEREO, 2.1V HALL, DOLBY PRO-LOGIC and THX.

INPUT IMPEDANCE

PHONO: 47K ohms and 65pF capacitance.
HIGH LEVEL: 22K ohms.

VOLTAGE GAIN

PHONO to TAPE: 40dB
PHONO to MAIN: 54dB
HIGH LEVEL to TAPE: 0dB
HIGH LEVEL to MAIN: 14dB

STONE CONTROLS

Bass and Treble variable 12dB boost to 12dB cut.

AC POWER OUTLETS

1 switched for accessories
1 switched for Area A power amplifier.
1 switched for Area B power amplifier.

POWER REQUIREMENTS

120 Volts, 50760Hz, 35 watts.

MECHANICAL INFORMATION

SIZE

Front Panel: 17 1/2 inches (44.5cm) Wide, 7 1/8 inches (18cm) High. Depth behind front panel including clearance for connectors, 17 1/2 inches (44.5cm). Knob clearance required in front of the mounting panel is 1-1/8 inches (2.9cm).

FINISH

The front panel is all glass with gold/teal nomenclature illumination. The chassis is black.

WEIGHT

30 pounds (13.6Kg) net, 42 pounds (19Kg) in shipping carton

CUSTOM INSTALLATION DRAWING

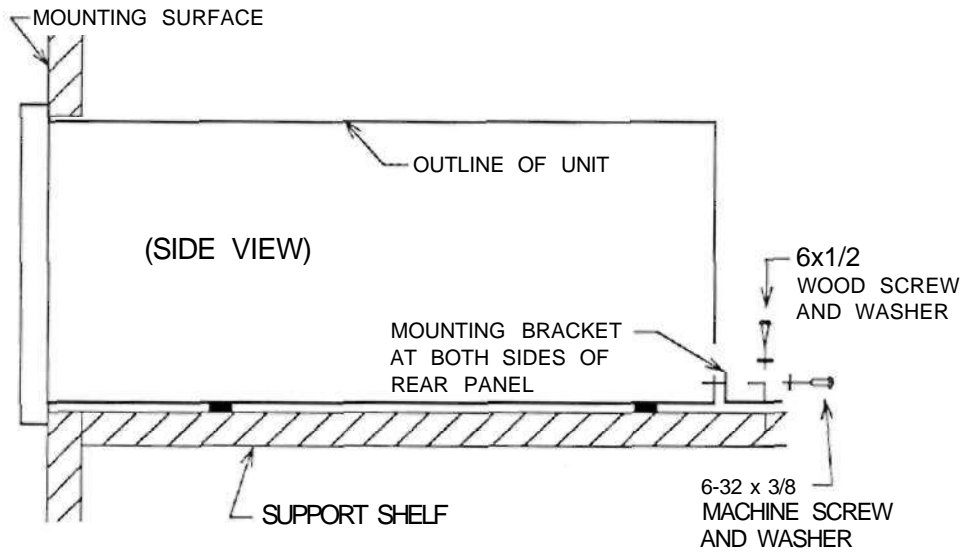
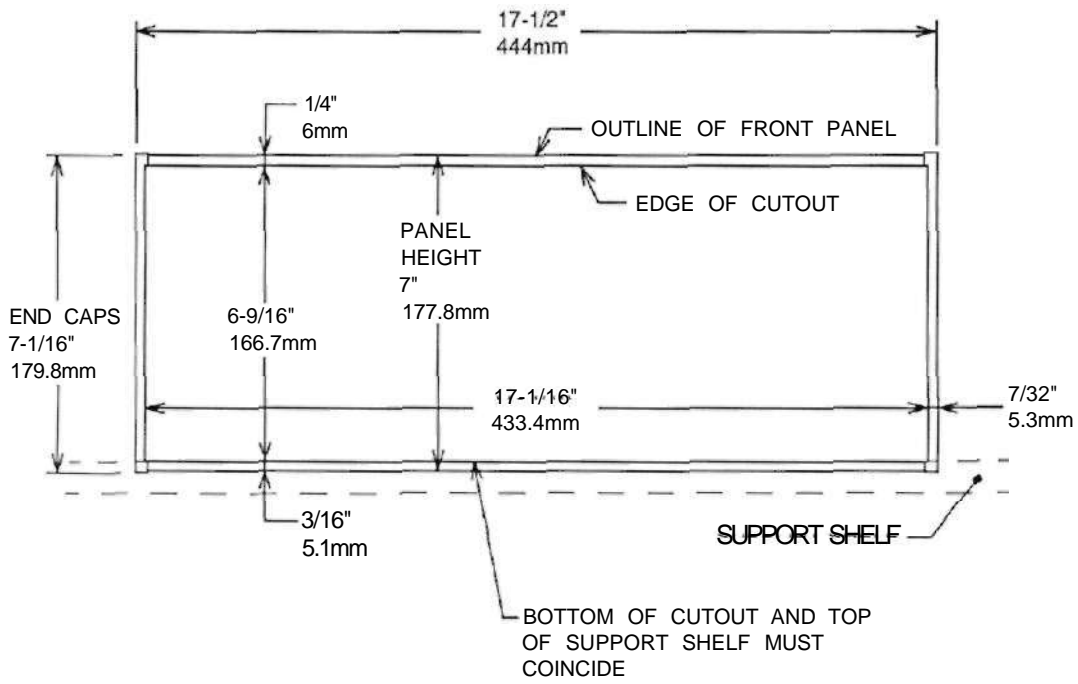

The letters and numbers correspond to the paragraphs on pages 8 through 21.

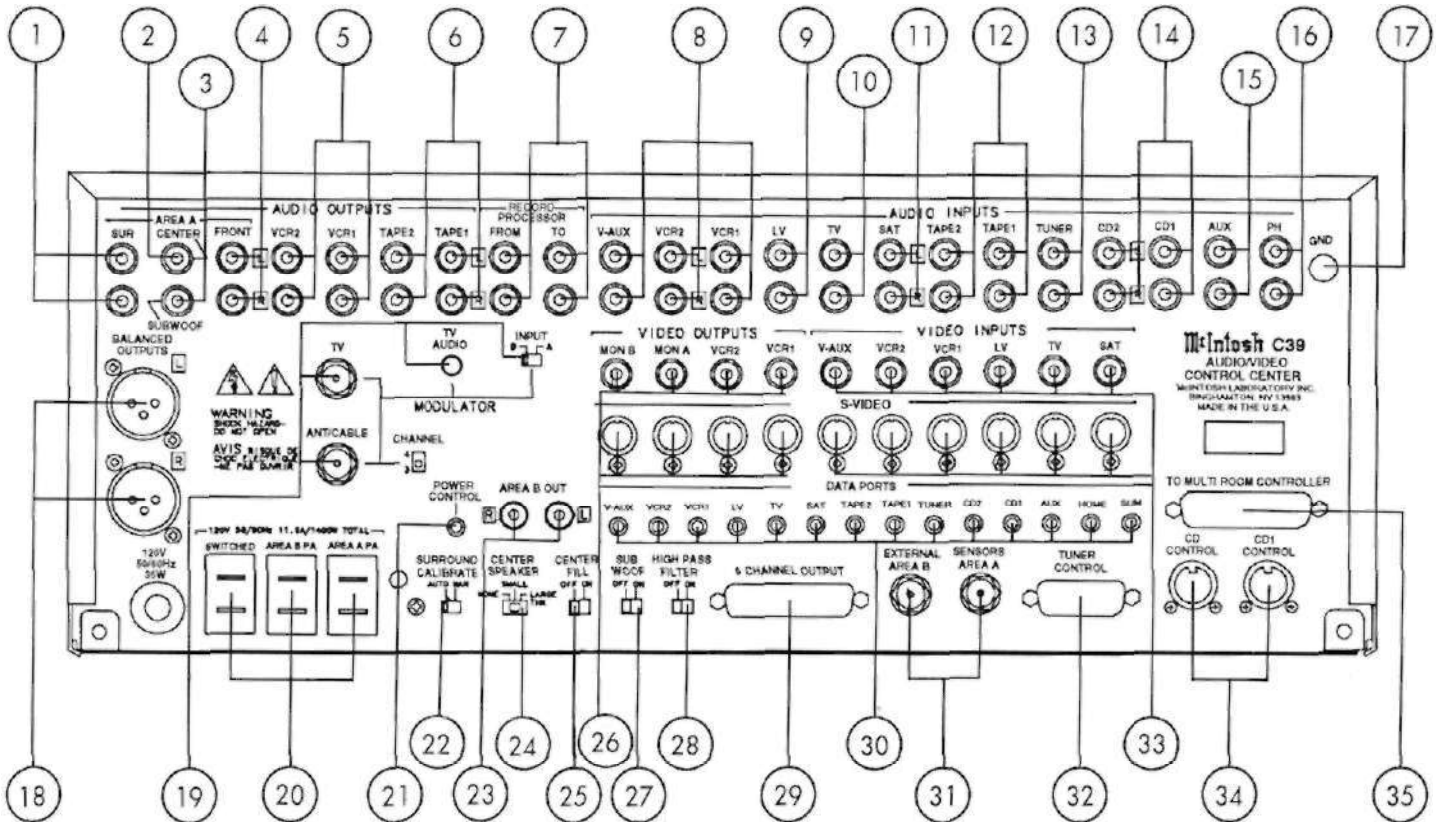
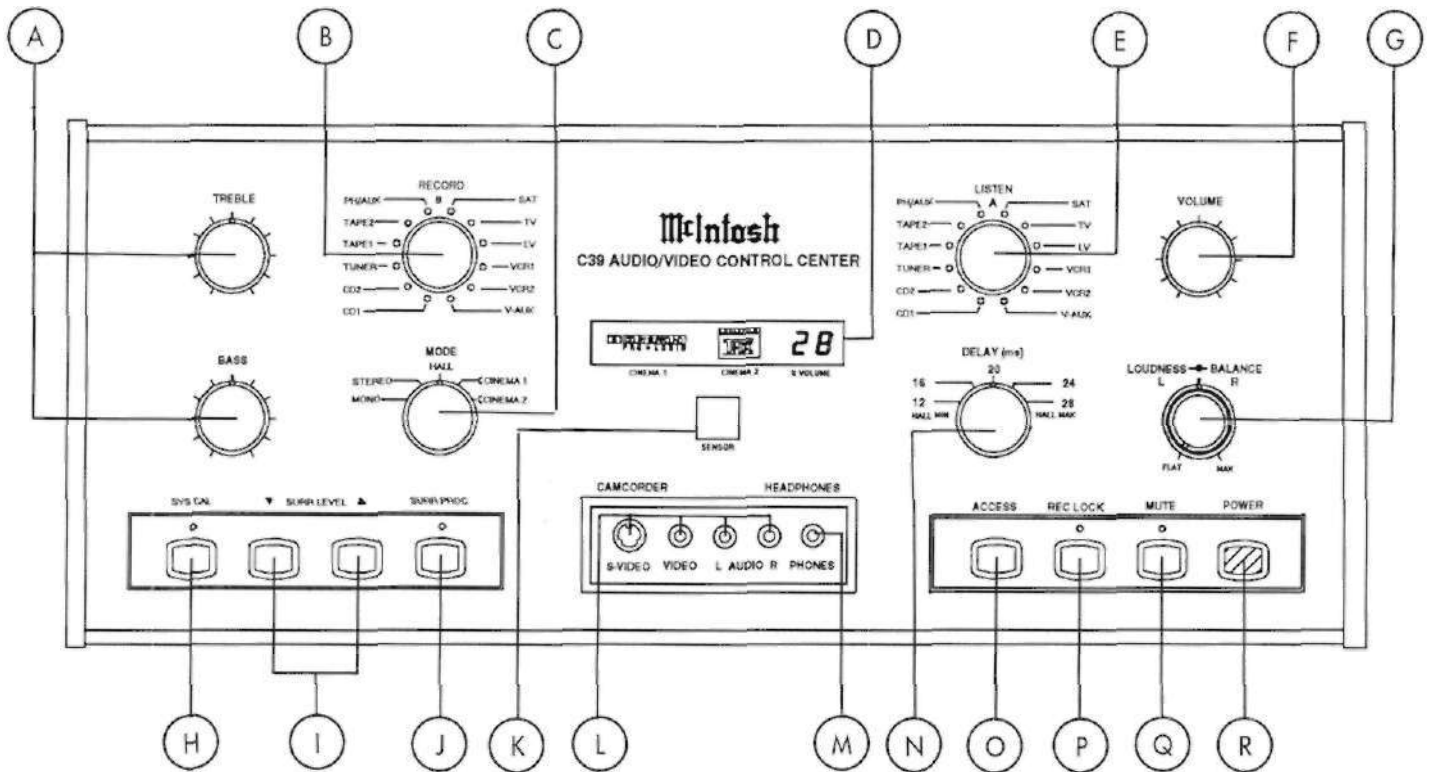

1911

THE UNIVERSITY OF CHICAGO
CHICAGO, ILLINOIS

1911



McINTOSH LABORATORY INC.
2 CHAMBERS STREET, BINGHAMTON, NEW YORK 13903-2699

The continuous improvement of its products is the policy of McIntosh Laboratory
Incorporated who reserve the right to improve design without notice.
Printed in the U.S.A.